

# VS1MD AC DRIVES



**Sensorless Vector micro drive that is compact, cost effective, and provides powerful control functions while maintaining a user-friendly operator interface.**

The VS1MD is a feature rich V/Hz and Sensorless Vector product targeted at both the equipment manufacturing and end user markets. Combining performance with an intuitive operator interface, the VS1MD can handle the most demanding applications.

## Features

- Input Voltages / Power Ratings
  - 240 Vac: 0.5 to 30 Hp
  - 480 Vac: 0.5 to 30 Hp
- Enclosures / Mounting
  - IP20/UL open type
  - IP20/UL Type 1 with optional NEMA 1 conduit kit installed
- Control Modes
  - V/Hz (Fan/Pump, Linear, Custom)
  - Sensorless Vector
  - Auto tune common motor settings
- Operator Interface
  - User friendly control
  - Basic start/stop, forward/reverse and speed control
  - LED Display; four character
  - Basic parameter group for quick start up
  - Remote keypad option (copycat capable)
- Operation Functions
  - Power - Off braking
  - High dc bus avoidance circuit
  - Torque boost
  - Electronic brake control
  - Skip frequencies (3)
  - Local/Remote Control
  - Digital Output On/Off Delay
  - Digital Input Timer
  - MOP Reference Input
  - Jog forward and reverse
  - Reverse disable
  - Slip compensation
  - Power-dip ride through & auto restart
  - PID control with sleep/wake function
  - Draw control
- RS485 Modbus-RTU Standard (built-in)
  - Interface for PC based software
  - Ability to multi-drop control from a PLC

## Specifications

- Digital Inputs (8)
  - Fully configurable
  - Factory set to common defaults
  - 24 Vdc sink / source
- Digital Outputs (2)
  - NO/NC Relay Output
  - Optically Isolated Output
- Analog Inputs (2)
  - 0 to 10V or -10 to 10V
  - 4 to 20mA
  - 10 bit resolution
- Analog Output (1)
  - 0 to 10V
  - Proportional to frequency, current, voltage or dc voltage
  - 10 bit resolution
- Preset Speeds (8)
  - Independent accel/decel ramps
- Fault Memory
  - Last (5) fault history
- Environmental
  - 10 to 50°C (higher available w/derate)
  - 3300 feet (1000m) Altitude w/o derate
  - 10 to 90% Humidity, non-condensing
- Electrical
  - Input voltage  $\pm 10\%$  of nominal, 48 ~ 63 Hz
  - 97% efficiency @ full load and frequency
- Output Ratings
  - 150% for 1 minute, 200% for 12 seconds
  - 0.01 to 400Hz output frequency
  - 1 to 15KHz switching frequency

## VS1MD Catalog Number Definition

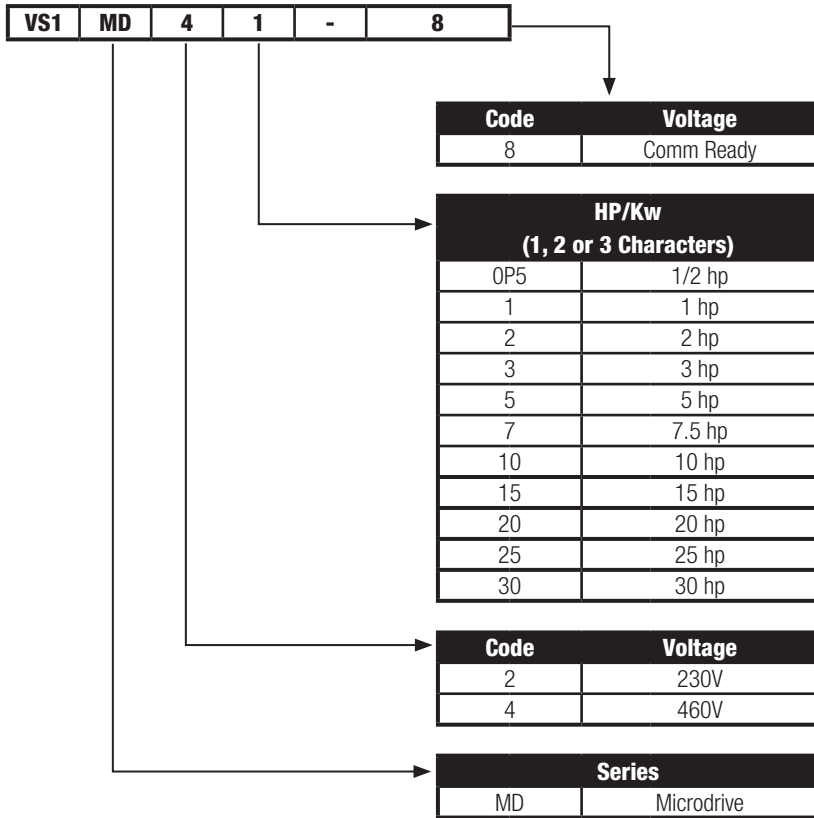

### Agency Certifications / Listings:

- UL
- cUL
- CE

### Optional Equipment and Accessories:

- Remote Keypad:
 

6.6 ft. (2 meter) cable	VS1MD-RKEY2
9.8 ft. (3 meter) cable	VS1MD-RKEY3
16.4 ft. (5 meter) cable	VS1MD-RKEY5
- NEMA 1 Conduit Kit
 

0.5 & 1 Hp (Frame A)	VS1MD-NM1A
2 Hp (Frame B)	VS1MD-NM1B
3 & 5 Hp (Frame C)	VS1MD-NM1C
7.5 & 10 Hp (Frame D)	VS1MD-NM1D
- DIN Rail Kit
 

Frame A	VS1MD-DINA
Frame B	VS1MD-DINB
Frame C	VS1MD-DINC
Frame D	VS1MD-DIND
- CopyCat Keypad VS1MD-CCL
- DeviceNet Card VS1MD-DNET

DB Resistors (see product catalog for complete list of available braking kitst)

## VS1MD Connections

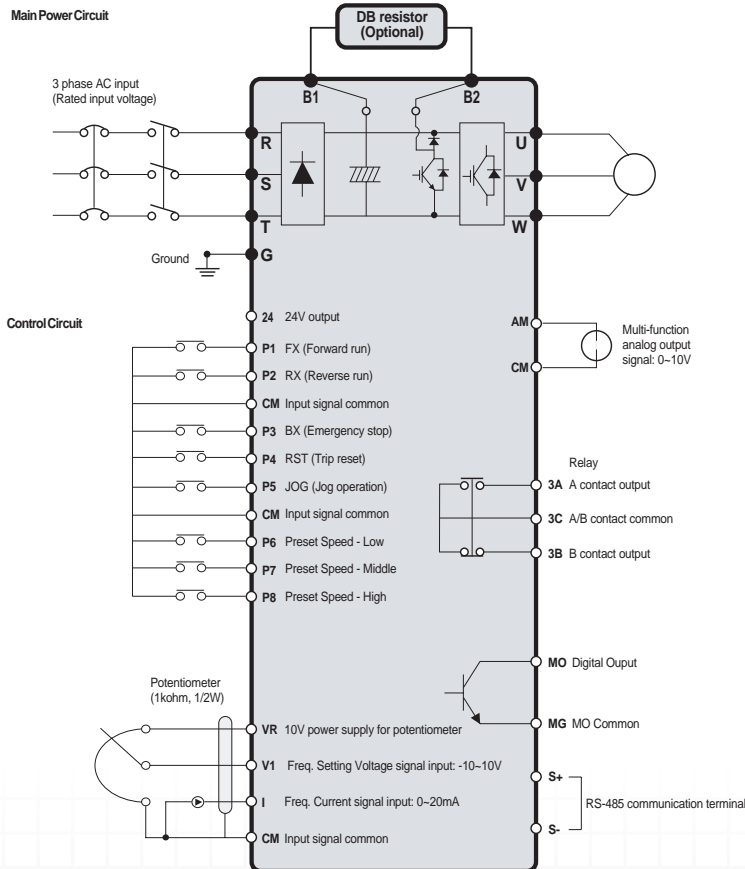

## Terminal Description Chart

Control Terminal	Description	Specification
P1 to P8	Digital Input 1 to 8	
CM	Common terminal	
VR	+10 Volts	Output voltage: 12V Output current: 100mA Potentiometer: 1-5kohm
V1	Analog Input: Voltage	-12V to +12V Input
I	Analog Input: Current	0 to 20mA Input Internal resistor: 500 ohm
AM	Analog Output	0 to 10V, 100mA maximum
CM	Common terminal	
MO	Digital Output	Below DC 26V, 100mA
MG	Digital Output Common	
24	+24 Volts	+24V, 100mA
S+/S-	RS-485 Communication terminal	
3A	Relay Output N.O. contact	250V AC 1 Amp
3B	Relay Output N.C. contact	30V DC 1 Amp
3C	Common for 3A & 3B contact	
Power Terminal	Description	
R, S, T	AC Line Input	
B1, B2	Connection for DB Resistor (Option)	
U, V, W	Connection terminal for motor	
G	Ground	

## Operation – Using the Keypad:

**Increase/Decrease:** In operation mode, arrows increase or decrease the speed reference. Used to navigate between parameters in edit mode.

**Left /Right:** In operation mode, arrows Change motor direction used to select parameter groups in edit mode.

**Enter/Prog:** Access the parameters menu by holding the Enter/Prog key for > 2 seconds. Used to display a parameter and store a new value into memory.

**Stop:** Stop the drive.

**Start:** Run the drive in keypad operation mode.

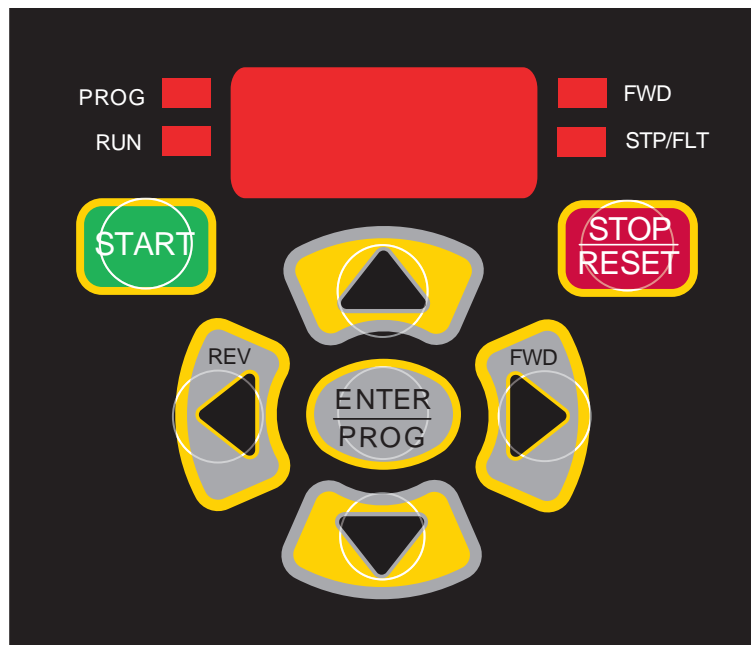

## Parameter Groups:

Drive parameters are organized in four program groups and one display group:

(d) Display Group Basic Display Parameters for common motor data such as speed, voltage and current.

(P) Program Group Basic startup parameters to run the drive. Start/stop source, speed reference, motor settings and accel/decel times are examples.

(F) Function Group Basic function parameters to adjust output speed/voltage, min/max speeds and braking.

(H) Advanced Group Advanced Drive Functions such as PID.

(t) Terminal Group Parameters needed to configure the digital/ analog Inputs and Outputs

Keypad Display	Parameter Name
P00	Jump Code
P30	Motor Hp
P32	Motor Rated Current
P33	Motor Pole Number
P34	Motor Base Frequency
P35	Frequency Low Limit
P36	Frequency High Limit
P37	Frequency Command
P38	Drive Control Mode
P39	Stop Method
P40	Frequency Method
P41	Acceleration Time
P42	Deceleration Time
P43	Preset Speed 1
P44	Preset Speed 2
P45	Preset Speed 3
P46	Run Source 2
P47	Frequency Control 2
P48	PID Control Value

# VS1MD AC DRIVES

## Ratings and Dimensions:

Model Number	Hp	kW	Input Current (Amps)	Output Current (Amps)	Frame	Weight Lbs (Kg)
<b>230V 50/60Hz 3-Phase</b>						
VS1MD20P5	0.5	0.4	3.9	2.5	A	1.67 (0.76)
VS1MD21	1	0.75	6.6	5	A	1.67 (0.76)
VS1MD22	2	1.5	9.9	8	B	2.47 (1.12)
VS1MD23	3	2.2	14.5	12	C	4.17 (1.89)
VS1MD25	5	3.7	21	16	C	4.17 (1.89)
VS1MD27	7.5	5.5	35	24	D	8.07 (3.66)
VS1MD210	10	7.5	48	32	D	8.07 (3.66)
VS1MD215	15	11	58	46	E	tbd
VS1MD220	20	15	69	60	E	tbd
VS1MD225	25	18.5	88	74	F	tbd
VS1MD230	30	22	96	88	F	tbd
<b>460V 50/60Hz 3-Phase</b>						
VS1MD40P5	0.5	0.4	1.7	1.25	A	1.67 (0.76)
VS1MD41	1	0.75	3.6	2.5	A	1.67 (0.76)
VS1MD42	2	1.5	5.3	4	B	2.47 (1.12)
VS1MD43	3	2.2	7.2	6	C	4.17 (1.89)
VS1MD45	5	3.7	10.5	8	C	4.17 (1.89)
VS1MD47	7.5	5.5	11.9	12	D	8.07 (3.66)
VS1MD410	10	7.5	24	16	D	8.07 (3.66)
VS1MD415	15	11	39	24	E	tbd
VS1MD420	20	15	44	30	E	tbd
VS1MD425	25	18.5	57	39	F	tbd
VS1MD430	30	22	57	45	F	tbd

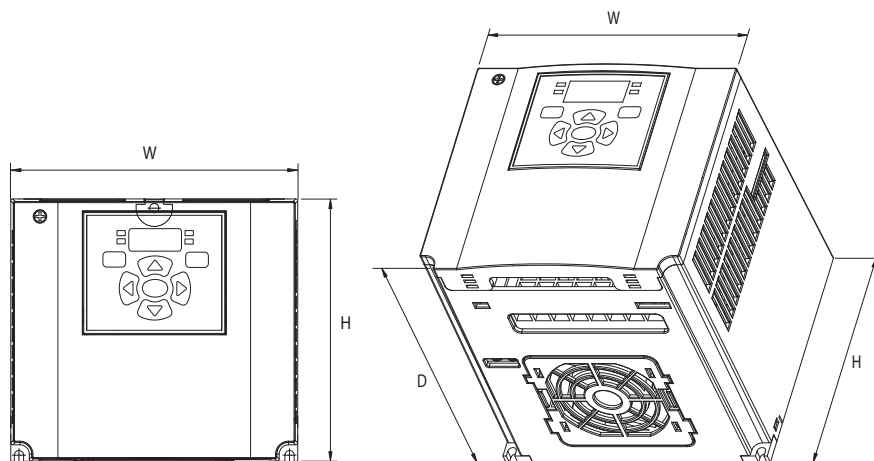

Dimensions - inches (mm)			
Frame	H	W	D
<b>VS1MD Micro Drive</b>			
A	5.04 (128)	2.75 (70)	5.12 (130)
B	5.04 (128)	3.94 (100)	5.12 (130)
C	5.04 (128)	5.20 (140)	6.10 (155)
D	8.66 (180)	7.08 (180)	6.69 (170)
E	15.40 (320)	11.30 (235)	9.12 (189.5)
F	19.73 (410)	12.50 (260)	10.03 (208.5)



**Baldor Electric Company**

P.O. Box 2400 • Fort Smith, AR 72902-2400 U.S.A.

Phone (479) 646-4711 • Fax (479) 648-5792 • International Fax (479) 648-5895 • www.baldor.com